

### ◎ POWER RATING

Engine Speed rev/min	Type of Operation	Engine Power	
		kWm	Ps
1800	Continuous Power	87	118
	Prime Power	96	130
	Standby Power	105	143
1500	Continuous Power	70	95
	Prime Power	77	105
	Standby Power	85	116



Note : -. The engine performance corresponds to ISO 3046, BS 5514 and DIN 6271.

-. Ratings are based on ISO 8528.

→ **Prime power** available at variable load. The permissible average power out put (during 24h period) shall not exceed 70% of the prime power rating.

→ **Standby power** available in the event of a main power network failure. No overload is permitted.

### ◎ MECHANICAL SYSTEM

○ Engine Model	D1146
○ Engine Type	In-line 4 cycle, water cooled Naturally aspirated
○ Combustion type	Direct injection
○ Cylinder Type	Replaceable dry liner
○ Number of cylinders	6
○ Bore x stroke	111(4.37) x 139(5.47) mm(in.)
○ Displacement	8.071(492.49) lit.(in <sup>3</sup> )
○ Compression ratio	17.5 : 1
○ Firing order	1-5-3-6-2-4
○ Injection timing	15° BTDC
○ Compression pressure	Above 28 kg/cm <sup>2</sup> (398 psi) at 200rpm
○ Dry weight	Approx. 720 kg (1,587 lb)
○ Dimension (LxWxH)	1,224 x 727 x 973 mm (48.2 x 28.6 x 38.3 in.)
○ Rotation	Counter clockwise viewed from Flywheel
○ Fly wheel housing	SAE NO.2
○ Fly wheel	Clutch NO.11 1/2

### ◎ MECHANISM

○ Type	Over head valve
○ Number of valve	Intake 1, exhaust 1 per cylinder
○ Valve lashes at cold	Intake 0.30mm (0.0118 in.) Exhaust 0.30mm (0.0118 in.)

### ◎ VALVE TIMING

	Opening	Close
○ Intake valve	16 deg. BTDC	36 deg. ABDC
○ Exhaust valve	46 deg. BBDC	14 deg. ATDC

### ◎ FUEL CONSUMPTION

○ Prime Power (lit/hr)	1,500 rpm	1,800 rpm
25%	7.5	8.9
50%	11.3	13.6
75%	15.9	19.0
100%	20.6	24.7
○ Standby Power (lit/h)	1,500 rpm	1,800 rpm
25%	7.7	9.2
50%	11.6	14.9
75%	16.1	20.8
100%	20.8	26.6

### ◎ FUEL SYSTEM

○ Injection pump	Zexel in-line “AD” type
○ Governor	RSV type ( all speed control )
○ Feed pump	Mechanical type
○ Injection nozzle	Multi hole type
○ Opening pressure	214 kg/cm <sup>2</sup> (3,044 psi)
○ Fuel filter	Full flow, cartridge type
○ Used fuel	Diesel fuel oil

### ◎ LUBRICATION SYSTEM

○ Lub. Method	Fully forced pressure feed type
○ Oil pump	Gear type driven by crankshaft
○ Oil filter	Full flow, cartridge type
○ Oil pan capacity	High level 15.5 liters ( 4.09 gal.) Low level 12 liters ( 3.17 gal.)
○ Angularity limit	Front down 25 deg. Front up 25 deg. Side to side 25 deg.
○ Lub. Oil	Refer to Operation Manual

## ◎ COOLING SYSTEM

- Cooling method      Fresh water forced circulation
- Water capacity      14 liters ( 3.70 gal.)
- (engine only)
- Pressure system     Max. 0.9 kg/cm<sup>2</sup> ( 12.8 psi)
- Water pump          Centrifugal type driven by belt
- Water pump Capacity 150 liters ( 39.6 gal.)/min
- at 1,800 rpm (engine)
- Thermostat         Wax – pellet type
- Opening temp. 71°C
- Full open temp. 85°C
- Cooling fan         Blower type, steel
- 590 mm diameter, 6 blade

## ◎ ELECTRICAL SYSTEM

- Charging generator 24V x 45A [or 12V x 26A ] Aalternator
- Voltage regulator    Built-in type IC regulator
- Starting motor        24V x 4.5kW [or 12V x 2.5kW ]
- Battery Voltage      24V [or 12V ]
- Battery Capacity     100 AH [or 150 AH ] (recommended)
- Starting aid (Option) Block heater

## ◎ ENGINEERING DATA

- Water flow            130 liters/min @1,500 rpm
- 150 liters/min @1,800 rpm
- Heat rejection to coolant 16.5 kcal/sec @1,800 rpm
- Air flow                5.8 m<sup>3</sup>/min @1,500 rpm
- 6.9 m<sup>3</sup>/min @1,800 rpm
- Exhaust gas flow     18.8 m<sup>3</sup>/min @1,800 rpm
- Exhaust gas temp.    620 °C @1,800 rpm
- Max. permissible restrictions
- .Intake system      220 mmH<sub>2</sub>O initial
- 635 mmH<sub>2</sub>O final
- .Exhaust system    1,000 mmH<sub>2</sub>O max.

## ◆ CONVERSION TABLE

- |                                    |                                    |
|------------------------------------|------------------------------------|
| in. = mm x 0.0394                  | lb/ft = N.m x 0.737                |
| PS = kW x 1.3596                   | U.S. gal = lit. x 0.264            |
| psi = kg/cm <sup>2</sup> x 14.2233 | kW = 0.2388 kcal/s                 |
| in <sup>3</sup> = lit. x 61.02     | lb/PS.h = g/kW.h x 0.00162         |
| hp = PS x 0.98635                  | cfm = m <sup>3</sup> /min x 35.336 |
| lb = kg x 2.20462                  |                                    |

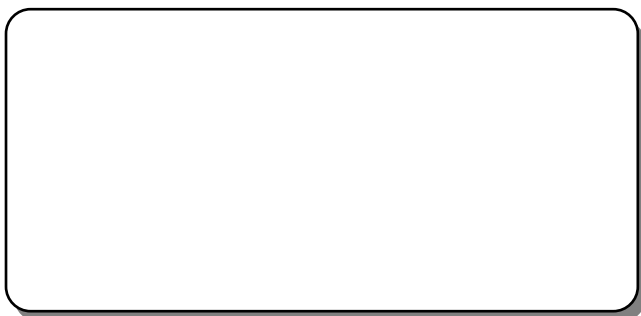
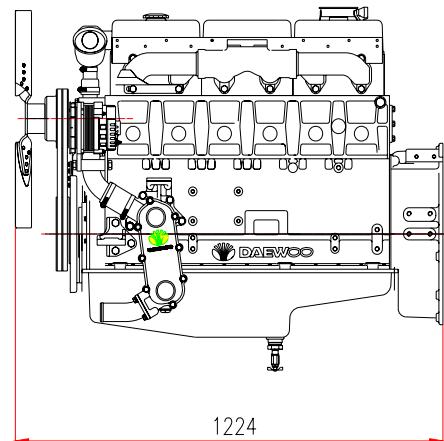
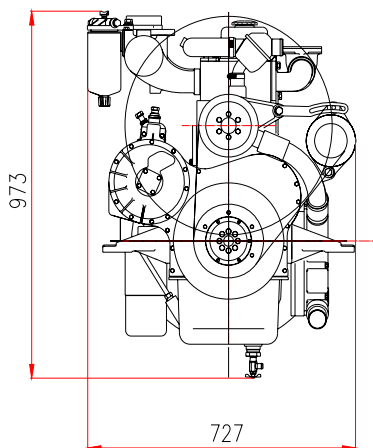

### Head office

7-11, Hwasu-Dong, Dong-Gu, Incheon, Korea  
**TEL : 82-32-760-1437, 1964 FAX : 82-32-760-1964**

### Seoul Office

Doosan Infracore Co. Ltd.,  
 22nd Floor, Doosan Tower, 18-12, Euljiro 6-ga, Jung-gu,  
 Seoul, Korea.

**TEL : 82-2-3398-8521~8535 FAX : 82-2-3398-8509**

**Web site : www.doosaninfracore.com**

※ Specifications are subject to change without prior notice