

◎ POWER RATING

RPM	Power rating kW(PS)	Torque N.m(kg.m)	Fuel consumption g/kW.h(g/PS.h)
1470	366 (498)	2384 (243)	192 (141)
1760	396 (538)	2148 (219)	199 (146)
2100	407 (553)	1854 (189)	216 (159)
2350	408 (555)	1658 (169)	234 (172)

Note : 1. The engine performance corresponds to ISO 3046.
 2. Engines are not to be used for continuous duty. Engines are to be used only for stationary emergency standby fire pump service.
 According to NFPA 25 engines are to be tested 30 minutes per week at no pump flow and full pump flow once per year.

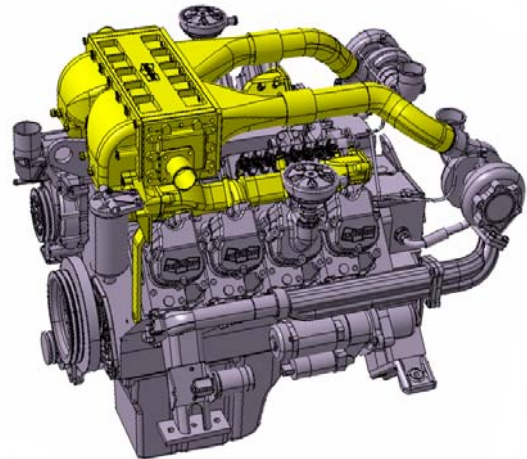

◎ MECHANICAL SYSTEM

- Engine Model PU158TI Fire Pump Driver
- Engine Type V-type 4 cycle, water cooled
Turbo charged & intercooled
- Combustion type Direct injection
- Cylinder Type Replaceable wet liner
- Number of cylinders 8
- Bore x stroke 128(5.04) x 142(5.59) mm(in.)
- Displacement 14.618 (892.0) lit.(in³)
- Compression ratio 14.6 : 1
- Firing order 1-5-7-2-6-3-4-8
- Injection timing 18° BTDC
- Dry weight Approx. 1,000 kg (2,205 lb)
- Dimension 1,229 x 1,140 x 1,205 mm
(LxWxH) (48.4 x 44.9 x 47.4 in.)
- Rotation Counter clockwise viewed from Flywheel
- Fly wheel housing SAE NO.1
- Fly wheel Clutch NO.14

◎ MECHANISM

- Type Over head valve
- Number of valve Intake 1, exhaust 1 per cylinder
- Valve lashes at cold Intake 0.25mm (0.0098 in.)
Exhaust 0.35mm (0.0138 in.)

◎ VALVE TIMING

- | | Opening | Close |
|-----------------|--------------|--------------|
| ○ Intake valve | 24 deg. BTDC | 36 deg. ABDC |
| ○ Exhaust valve | 63 deg. BBDC | 27 deg. ATDC |

◎ ENGINE EQUIPMENT

- Engine parts Fly wheel & housing
Intake & exhaust manifold
Water to air inter cooler
- Electrical parts Stop solenoid of ETS type (only EAZPB)

◎ FUEL SYSTEM

- Injection pump Bosch in-line "P" type
- Governor Mechanical type (only EAZPB)
Electrical type (only EAZPC)
- Feed pump Mechanical type
- Injection nozzle Multi hole type
- Fuel filter Full flow, cartridge type
- Used fuel Diesel fuel oil

◎ LUBRICATION SYSTEM

- Lub. Method Fully forced pressure feed type
- Oil pump Gear type driven by crankshaft
- Oil filter Full flow, cartridge type
- Oil pan capacity High level 28 liters (7.40 gal.)
Low level 26 liters (6.86 gal.)
- Angularity limit Front down 35 deg.
Front up 35 deg.
Side to side 35 deg.
- Lub. Oil Refer to Operation Manual

◎ COOLING SYSTEM

- Cooling method Fresh water forced circulation
- Water capacity 20 liters (5.28 gal.)
- Water pump Centrifugal type driven by belt
- Water pump Capacity 653 liters (173 gal.)/min
at 2,350 rpm (engine)
- Thermostat Wax – pellet type
Opening temp. 71°C
Full open temp. 85°C
- Water flow in intercooler
 - Critical velocity 2.0 m/s max.
 - Pressure drop 0.1 bar

PU158TI Fire Pump Driver

⊙ ELECTRICAL SYSTEM

- Charging generator 28.5V x 45A alternator
- Voltage regulator Built-in type IC regulator
- Starting motor 24V x 7.0kW
- Battery Voltage 24V
- Battery Capacity 200 AH (recommended)
- Starting aid (Option) Block heater

⊙ NOISE DATA

- Test Standards ISO-3744 / JIS-B8005
- Test Condition 1m at the Cylinder Block
- Calculated sound pressure

RPM	Power [PS]	Octave Band [dB(A)]
1760	538	100.0
2100	553	103.0
2350	555	104.5

◆ CONVERSION TABLE

- in. = mm x 0.0394
- lb/ft = N.m x 0.737
- PS = kW x 1.3596
- U.S. gal = lit. x 0.264
- psi = kg/cm² x 14.2233
- kW = 0.2388 kcal/s
- in³ = lit. x 61.02
- lb/PS.h = g/kW.h x 0.00162
- hp = PS x 0.98635
- cfm = m³/min x 35.336
- lb = kg x 2.20462

⊙ ENGINEERING DATA

- Water flow 653 liters/min @2,350 rpm
584 liters/min @2,100 rpm
489 liters/min @1,760 rpm
- Heat rejection to coolant 53.3 kcal/sec @2,350 rpm
47.6 kcal/sec @2,100 rpm
39.9 kcal/sec @1,760 rpm
- Heat rejection to CAC 30.2 kcal/sec @2,350 rpm
27 kcal/sec @2,100 rpm
20.6 kcal/sec @1,760 rpm
- Air flow 52.6 m³/min @2,350 rpm
49.2 m³/min @2,100 rpm
44.1 m³/min @1,760 rpm
- Exhaust gas flow 93.7 m³/min @2,350 rpm
81.1 m³/min @2,100 rpm
70.3 m³/min @1,760 rpm
- Exhaust gas temp. 572 °C @2,350 rpm
529 °C @2,100 rpm
512 °C @1,760 rpm
- Max. permissible restrictions
 - Intake system 220 mmH₂O initial
635 mmH₂O final
 - Exhaust system 600 mmH₂O max.

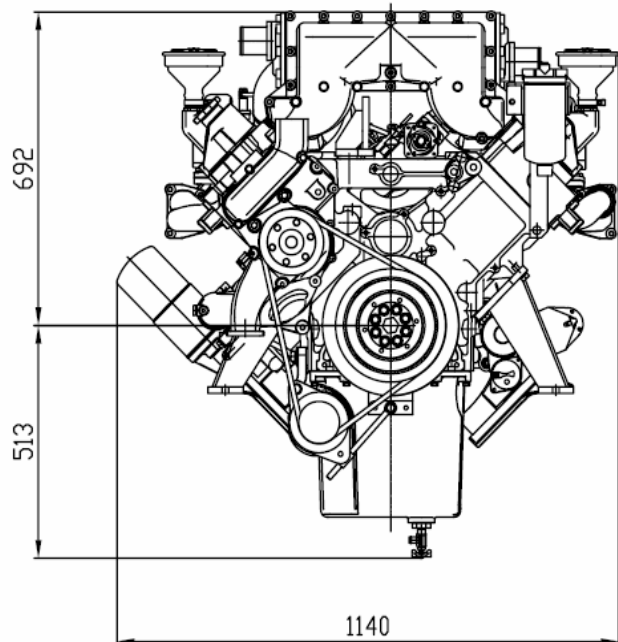
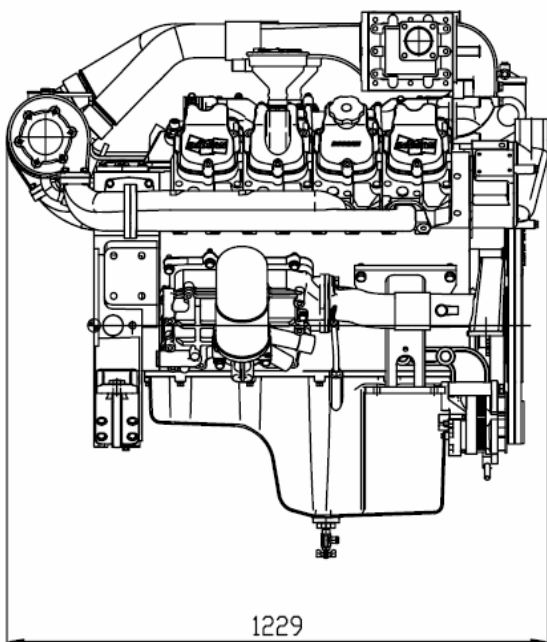

PU158TI Fire Pump Driver

◎ PERFORMANCE CURVE

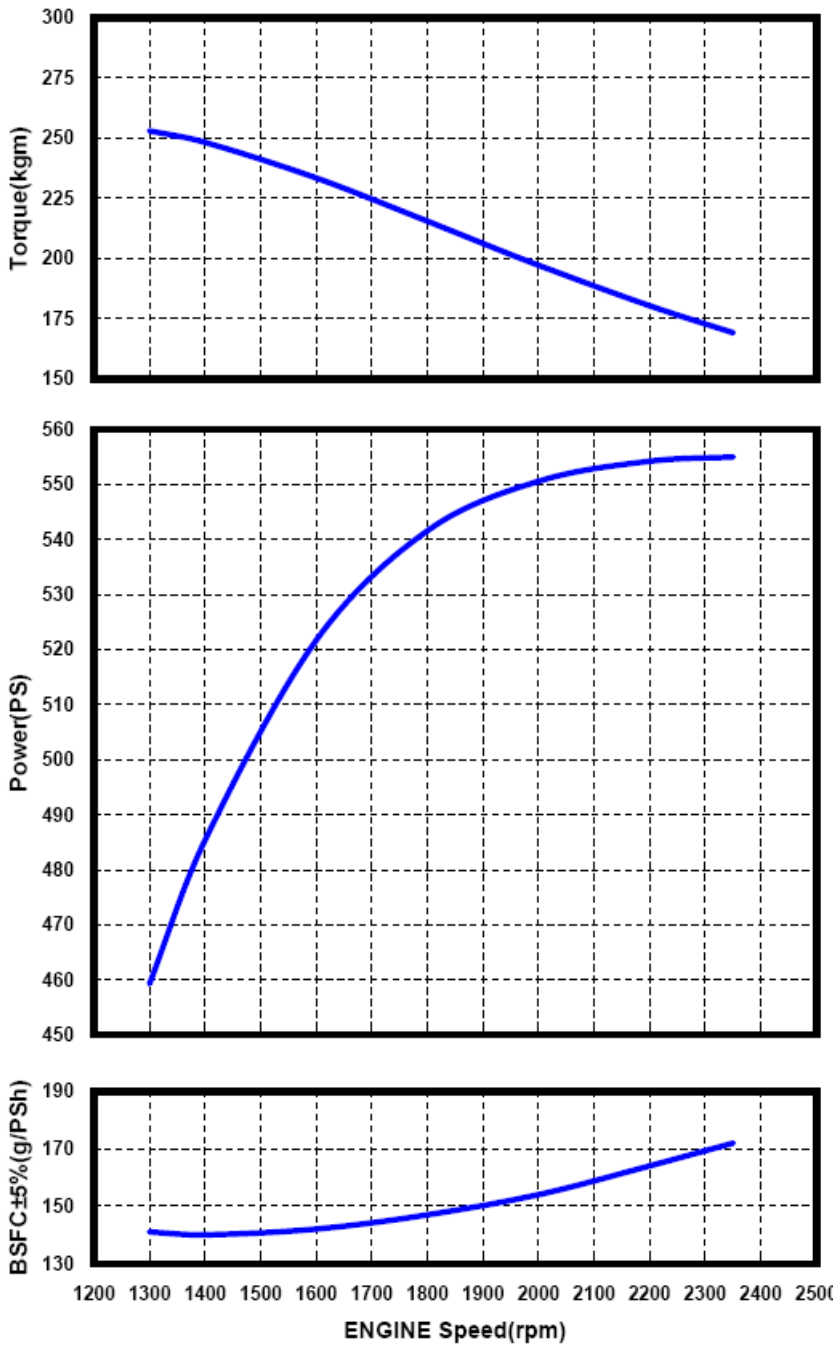

All data is based on the engine operating with fuel system, water pump, lubricating oil pump, air cleaner, and alternator; not included are compressor, fan, optional equipment, and driven components.

Data is based on operation at ISO standard 3046 conditions of 100 kPa barometric pressure, 100 m altitude, and 25 °C intake ambient temperature.

Engine is certified at any speed between 1470 and 2350 RPM.



Head office
 7-11, Hwasu-Dong, Dong-Gu, Incheon, Korea
TEL : 82-32-211-2222 FAX : 82-32-762-7384
Seoul Office
 Doosan Infracore Co. Ltd.,
 22nd Floor, Doosan Tower, 18-12, Euljiro 6-ga, Jung-gu,
 Seoul, Korea.
TEL : 82-2-3398-8521~8535 FAX : 82-2-3398-8509
Web site : www.doosaninfracore.com

※ Specifications are subject to change without prior notice