

### ◎ POWER RATING

Intermittent rating kW(PS) / rpm	Max. torque N.m(kg.m) / rpm	Fuel consumption g/kW.h(g/PS.h) / rpm
<b>228 (310) / 2,450</b>	<b>1177 (120) / 1,500</b>	<b>228 (168) / 2,450</b>

Note : 1. The engine performance corresponds to ISO 3046, DIN 6270B.

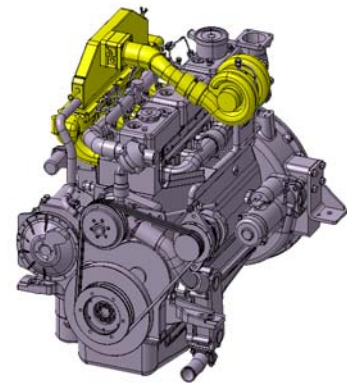

### ◎ MECHANICAL SYSTEM

- Engine Model                    PU086TI
- Engine Type                    In-line 4 cycle, water cooled  
Turbo charged & intercooled
- Combustion type                Direct injection
- Cylinder Type                  Replaceable dry liner
- Number of cylinders            6
- Bore x stroke                    111(4.37) x 139(5.47) mm(in.)
- Displacement                    8.071(492.49) lit.(in3)
- Compression ratio              16.7 : 1
- Firing order                      1-5-3-6-2-4
- Injection timing                18° BTDC
- Compression pressure        Above 28 kg/cm<sup>2</sup>(398 psi) at 200rpm
- Dry weight                        Approx. 800 kg (1,763 lb)
- Dimension  
(LxWxH)                            1,116 x 728 x 1,106 mm  
(43.9 x 28.6 x 43.5 in.)
- Rotation                          Counter clockwise viewed  
from Flywheel

### ◎ MECHANISM

- Type                                Over head valve
- Number of valve                Intake 1, exhaust 1 per cylinder
- Valve lashes at cold            Intake 0.30 mm(0.0118 in)  
Exhaust 0.30 mm(0.0118 in.)

### ◎ VALVE TIMING

- |                 | Opening      | Close        |
|-----------------|--------------|--------------|
| ○ Intake valve  | 16 deg. BTDC | 36 deg. ABDC |
| ○ Exhaust valve | 46 deg. BBDC | 14 deg. ATDC |

### ◎ OPTION & ACCESSORY PARTS

- Engine parts                    Fly wheel & housing  
Intake & exhaust manifold
- Accessory parts                -
- Electrical parts                Stop solenoid

### ◎ FUEL SYSTEM

- Injection pump                Zexel in-line "PE6P" type
- Governor                        RSV type(all speed control)
- Feed pump                        Mechanical type
- Injection nozzle                Multi hole type
- Opening pressure              224 kg/cm<sup>2</sup> (3,186 psi)
- Fuel filter                        Full flow, cartridge type
- Used fuel                         Diesel fuel oil

### ◎ LUBRICATION SYSTEM

- Lub. Method                    Fully forced pressure feed type
- Oil pump                         Gear type driven by crankshaft
- Oil filter                         Full flow, cartridge type
- Oil pan capacity                High level 15 liters ( 4.09 gal.)  
Low level 12 liters ( 3.17 gal.)
- Angularity limit                Front down 25 deg.  
Front up 25 deg.  
Side to side 25 deg.
- Lub. Oil                         Refer to Operation Manual

### ◎ PERFORMANCE CURVE

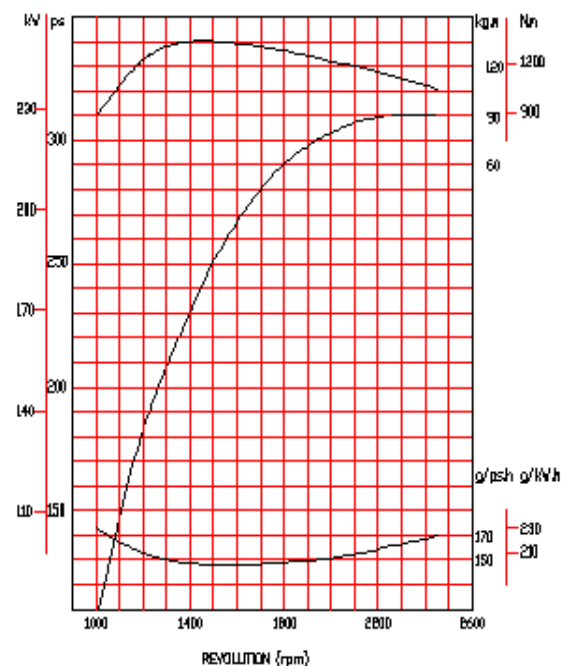

## ◎ COOLING SYSTEM

- Cooling method Fresh water forced circulation
- Water capacity 14 liters ( 3.70 gal.)  
(engine only)
- Pressure system Max. 0.5 kg/cm<sup>2</sup> ( 7.1 psi)
- Water pump Centrifugal type driven by belt
- Water pump Capacity 273 liters ( 60.1 gal.)/min  
at 2,450 rpm (engine)
- Thermostat Wax – pellet type  
Opening temp. 71°C  
Full open temp. 85°C
- Cooling fan -

## ◎ ELECTRICAL SYSTEM

- Charging generator 24V x 45A alternator
- Voltage regulator Built-in type IC regulator
- Starting motor 24V x 6.0kW
- Battery Voltage 24V
- Battery Capacity 100 AH (recommended)
- Starting aid (Option) Block heater

## ◎ ENGINEERING DATA

- Water flow 273 liters/min @ 2,450 rpm
- Heat rejection to coolant 33.9 kcal/sec @ 2,450 rpm
- Air flow 18.5 m<sup>3</sup>/min @ 2,450 rpm
- Exhaust gas flow 19.3 m<sup>3</sup>/min @ 2,450 rpm
- Exhaust gas temp. 544 °C @ 2,450 rpm
- Max. permissible restrictions
  - Intake system 220 mmH<sub>2</sub>O initial  
635 mmH<sub>2</sub>O final
  - Exhaust system 1,000 mmH<sub>2</sub>O max.

## ◎ INTERCOOLER DATA

- Heat rejection to coolant 10.5 kcal/sec @2,450 rpm

## ◆ CONVERSION TABLE

in. = mm x 0.0394	lb/ft = N.m x 0.737
PS = kW x 1.3596	U.S. gal = lit. x 0.264
psi = kg/cm <sup>2</sup> x 14.2233	kW = 0.2388 kcal/s
in <sup>3</sup> = lit. x 61.02	lb/PS.h = g/kW.h x 0.00162
hp = PS x 0.98635	cfm = m <sup>3</sup> /min x 35.336
lb = kg x 2.20462	

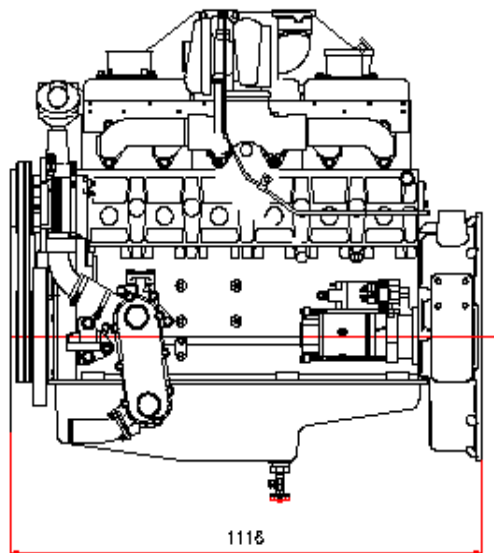
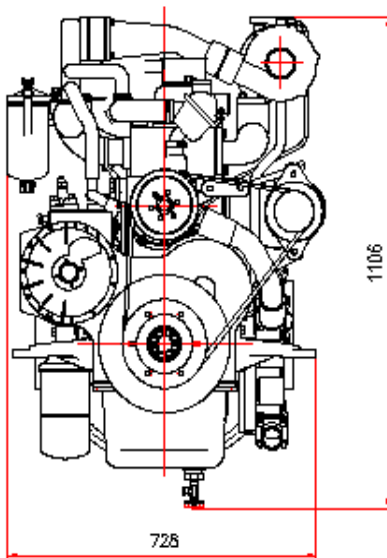

### Head office

7-11, Hwasu-Dong, Dong-Gu, Incheon, Korea  
 TEL : 82-32-211-2221 FAX : 82-32-762-7384

### Seoul Office

Doosan Infracore Co. Ltd.,  
 22nd Floor, Doosan Tower, 18-12, Euljiro 6-ga, Jung-gu,  
 Seoul, Korea.

TEL : 82-2-3398-8521~8535 FAX : 82-2-3398-8509  
 Web site : [www.doosaninfracore.com](http://www.doosaninfracore.com)

※ Specifications are subject to change without prior notice