

◎ POWER RATING

Intermittent rating kW(PS) / rpm	Max. torque N.m(kg.m) / rpm	Fuel consumption g/kW.h(g/PS.h) / rpm
121 (165) / 2,450	559 (57) / 1,500	231 (170) / 2,450

Note : 1. The engine performance corresponds to ISO 3046, DIN 6270B.

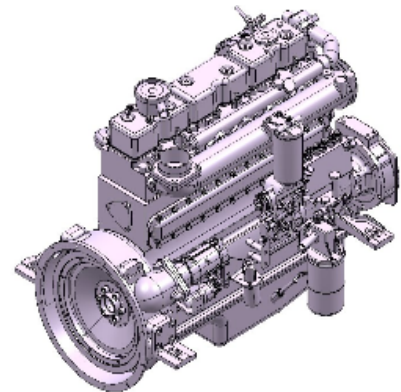

◎ MECHANICAL SYSTEM

- Engine Model PU086
- Engine Type In-line 4 cycle, water cooled
Naturally aspirated
- Combustion type Direct injection
- Cylinder Type Replaceable dry liner
- Number of cylinders 6
- Bore x stroke 111(4.37) x 139(5.47) mm(in.)
- Displacement 8.071(492.49) lit.(in3)
- Compression ratio 16.8 : 1
- Firing order 1-5-3-6-2-4
- Injection timing 18° BTDC
- Compression pressure Above 28 kg/cm²(398 psi) at 200rpm
- Dry weight Approx. 780 kg (1,720 lb)
- Dimension
(LxWxH) 1,117 x 759 x 977 mm
(43.9 x 29.8 x 38.5 in.)
- Rotation Counter clockwise viewed
from Flywheel

◎ MECHANISM

- Type Over head valve
- Number of valve Intake 1, exhaust 1 per cylinder
- Valve lashes at cold Intake 0.30 mm(0.0118 in)
Exhaust 0.30 mm(0.0118 in.)

◎ VALVE TIMING

- | | Opening | Close |
|-----------------|--------------|--------------|
| ○ Intake valve | 16 deg. BTDC | 36 deg. ABDC |
| ○ Exhaust valve | 46 deg. BBDC | 14 deg. ATDC |

◎ OPTION & ACCESSORY PARTS

- Engine parts Fly wheel & housing
Intake & exhaust manifold
- Accessory parts -
- Electrical parts Stop solenoid

◎ FUEL SYSTEM

- Injection pump Zexel in-line "AD" type
- Governor RSV type(all speed control)
- Feed pump Mechanical type
- Injection nozzle Multi hole type
- Opening pressure 214 kg/cm² (3,044 psi)
- Fuel filter Full flow, cartridge type
- Used fuel Diesel fuel oil

◎ LUBRICATION SYSTEM

- Lub. Method Fully forced pressure feed type
- Oil pump Gear type driven by crankshaft
- Oil filter Full flow, cartridge type
- Oil pan capacity High level 15 liters (4.09 gal.)
Low level 12 liters (3.17 gal.)
- Angularity limit Front down 25 deg.
Front up 25 deg.
Side to side 25 deg.
- Lub. Oil Refer to Operation Manual

◎ PERFORMANCE CURVE

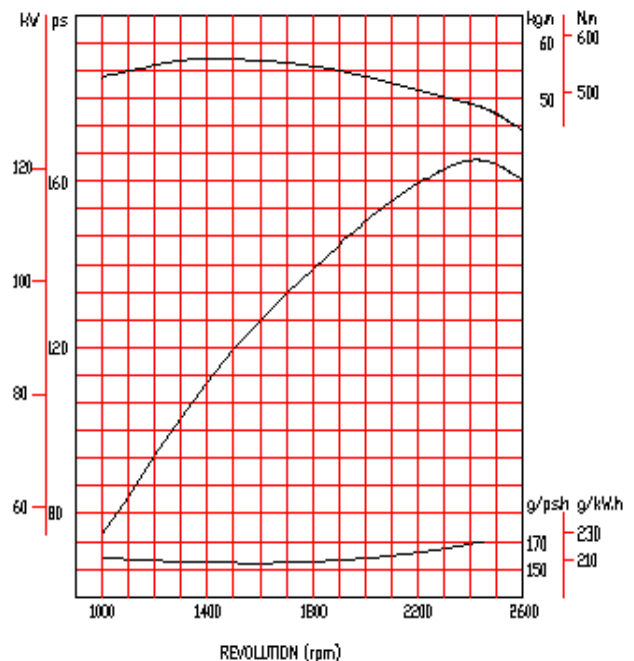

◎ COOLING SYSTEM

- Cooling method Fresh water forced circulation
- Water capacity 14 liters (3.70 gal.)
(engine only)
- Pressure system Max. 0.5 kg/cm² (7.1 psi)
- Water pump Centrifugal type driven by belt
- Water pump Capacity 273 liters (60.1 gal.)/min
at 2,450 rpm (engine)
- Thermostat Wax – pellet type
Opening temp. 71°C
Full open temp. 85°C
- Cooling fan Blower type, steel
590 mm diameter, 6 blade

◎ ELECTRICAL SYSTEM

- Charging generator 24V x 45A [or 12V x 26A] alternator
- Voltage regulator Built-in type IC regulator
- Starting motor 24V x 4.5kW [or 12V x 2.5kW]
- Battery Voltage 24V [or 12V]
- Battery Capacity 100 AH [or 150 AH](recommended)
- Starting aid (Option) Block heater

◎ ENGINEERING DATA

- Water flow 273 liters/min @2,450 rpm
- Heat rejection to coolant 17.7 kcal/sec @2,450 rpm
- Air flow 8.0 m³/min @2,450 rpm
- Exhaust gas flow 8.4 m³/min @2,450 rpm
- Exhaust gas temp. 674 °C @2,450 rpm
- Max. permissible restrictions
 - Intake system 220 mmH₂O initial
635 mmH₂O final
 - Exhaust system 1,000 mmH₂O max.

◆ CONVERSION TABLE

- | | |
|------------------------------------|------------------------------------|
| in. = mm x 0.0394 | lb/ft = N.m x 0.737 |
| PS = kW x 1.3596 | U.S. gal = lit. x 0.264 |
| psi = kg/cm ² x 14.2233 | kW = 0.2388 kcal/s |
| in ³ = lit. x 61.02 | lb/PS.h = g/kW.h x 0.00162 |
| hp = PS x 0.98635 | cfm = m ³ /min x 35.336 |
| lb = kg x 2.20462 | |

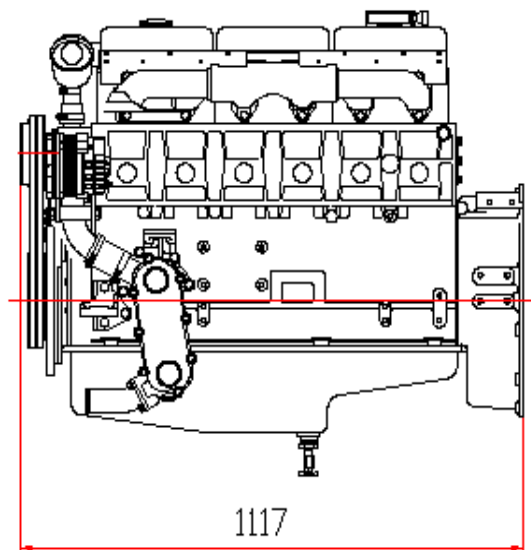
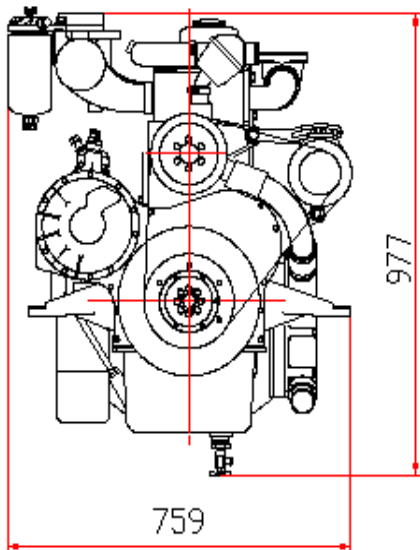

Head office

7-11, Hwasu-Dong, Dong-Gu, Incheon, Korea
TEL : 82-32-211-2221 FAX : 82-32-762-7384

Seoul Office

Doosan Infracore Co. Ltd.,
22nd Floor, Doosan Tower, 18-12, Euljiro 6-ga, Jung-gu,
Seoul, Korea.

TEL : 82-2-3398-8521~8535 FAX : 82-2-3398-8509

Web site : www.doosaninfracore.com